

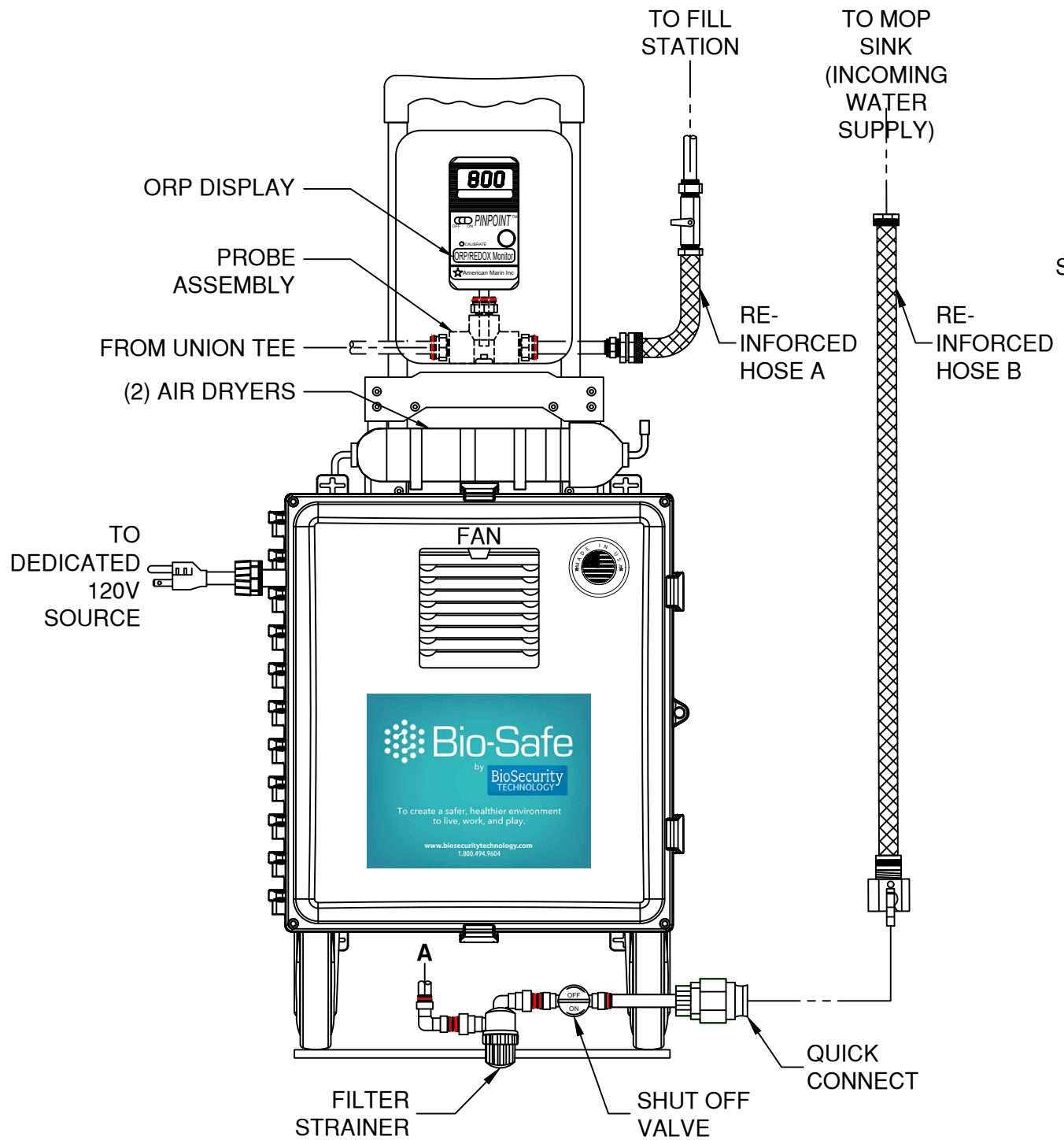

2 WHEEL CART 3.5 GPM

DRAWING INDEX		
DRAWING #	DRAWING DESCRIPTION	REVISION
2WHE2-01	COVER PAGE	1
2WHE2-02	INSTALLATION	1
2WHE2-03	DIMENSIONS	1



FRONT VIEW

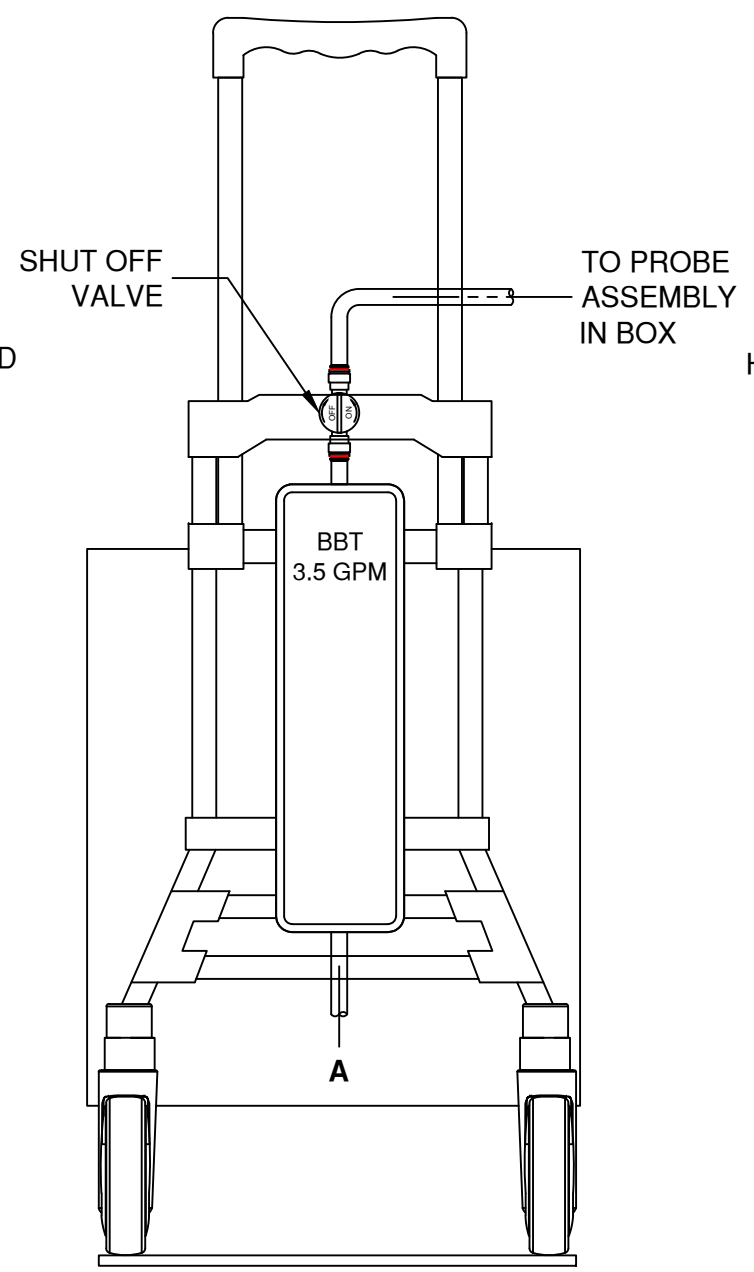

REAR VIEW

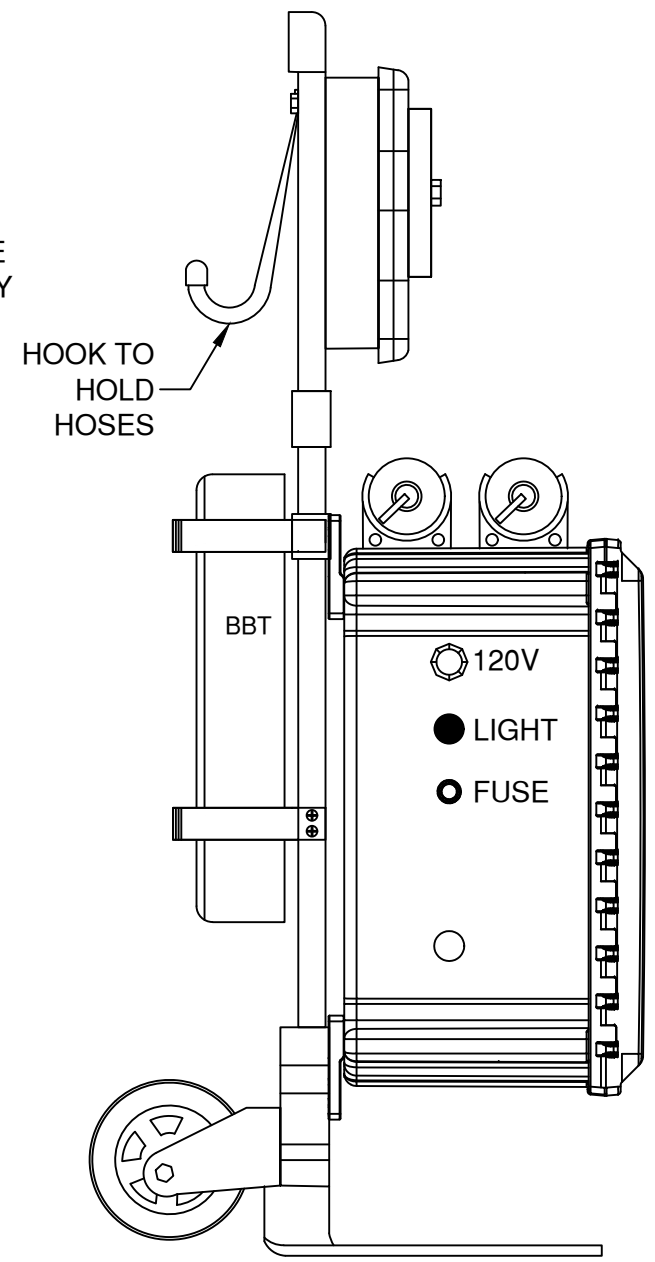

LEFT VIEW

BIO-SAFE INSTALLATION

1. PLUG POWER CORD FROM BIO-SAFE UNIT INTO 120V POWER SUPPLY.
2. MUST BE DEDICATED 120V POWER OUTLET.
3. TURN ON ORP DISPLAY.
4. CONNECT REINFORCED HOSE A TO FILL STATION.
5. CONNECT REINFORCED HOSE B TO MOP SINK (INCOMING WATER SUPPLY)

NOTE:
BBT = BLACKBOX TECHNOLOGY

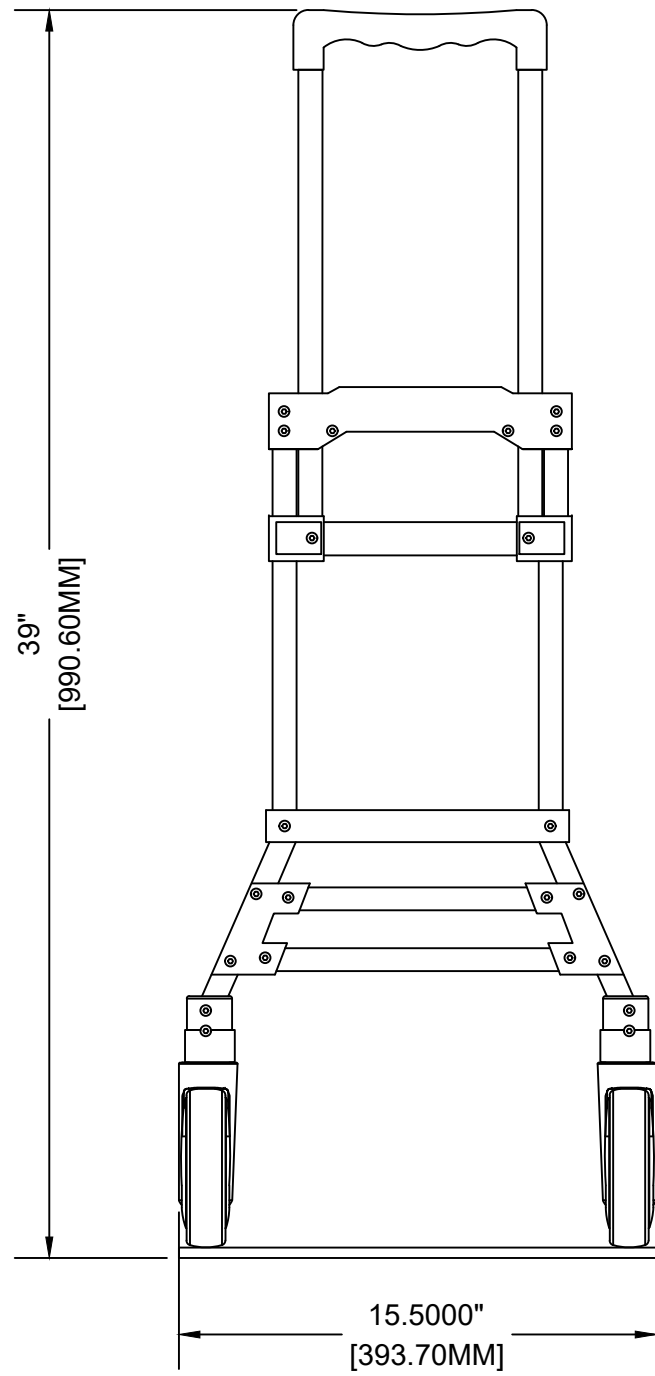

FRONT VIEW

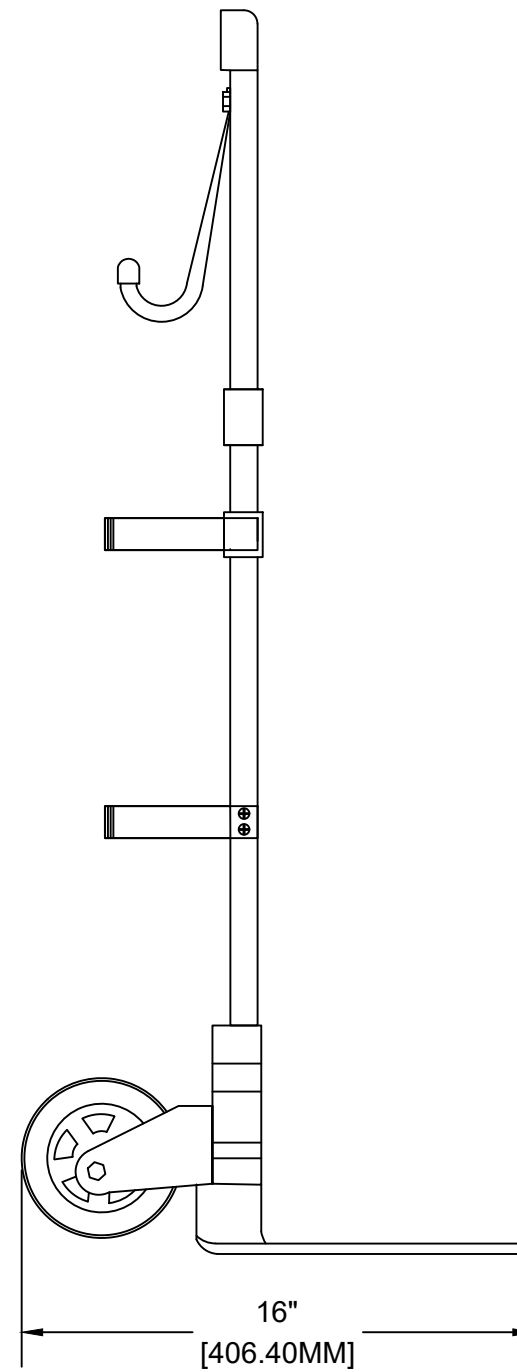

RIGHT VIEW