

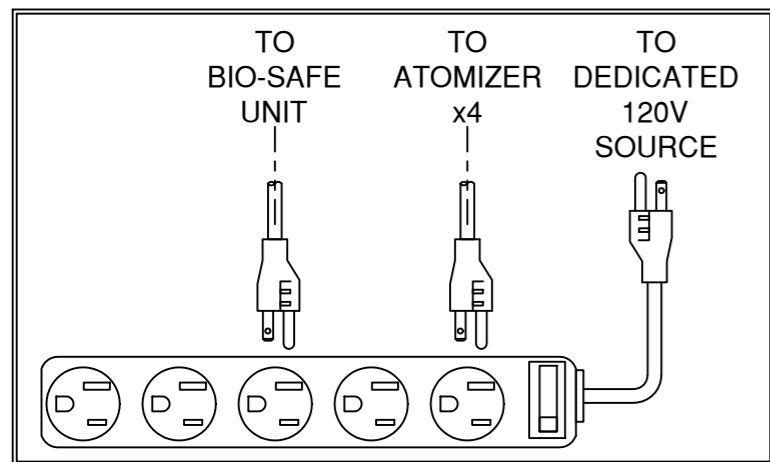

4 WHEEL CART 1.5/3.5 GPM COMBINATION

DRAWING INDEX		
DRAWING #	DRAWING DESCRIPTION	REVISION
4WHE3-01	COVER PAGE	1
4WHE3-02	INSTALLATION	1
4WHE3-03	DIMENSIONS	1

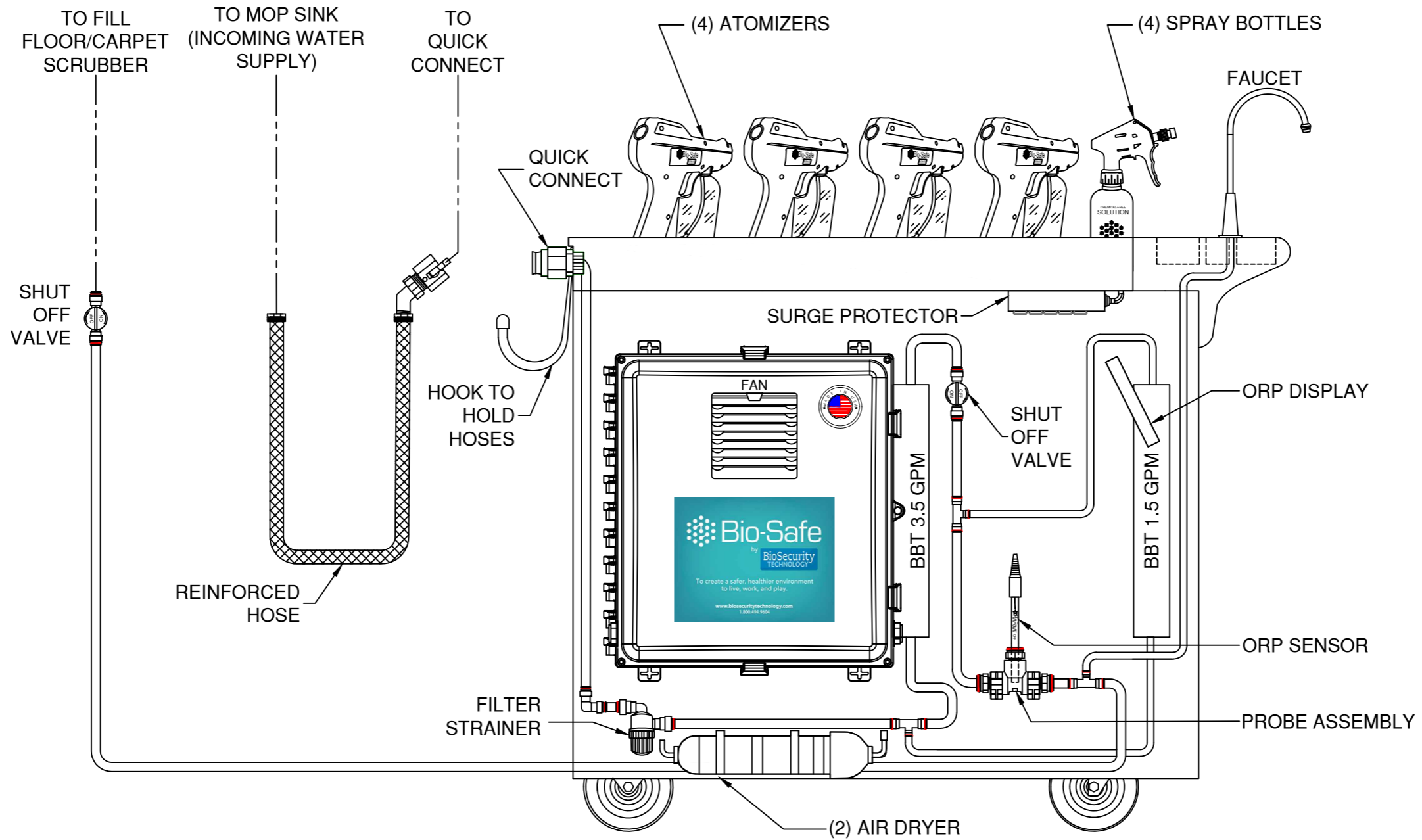

DETAIL A
SURGE PROTECTOR

BIO-SAFE INSTALLATION

1. PLUG UTILITY CART INTO MOP SINK.
2. PLUG UTILITY CART SURGE PROTECTOR INTO 120V POWER SUPPLY.
3. MUST BE DEDICATED 120V POWER OUTLET.
4. TURN ON ORP DISPLAY.
5. FILL ATOMIZER AND SPRAY BOTTLE FROM FAUCET.
6. FILL CARPET/FLOOR MACHINE FROM REINFORCED HOSE.

NOTE:
BBT = BLACKBOX TECHNOLOGY

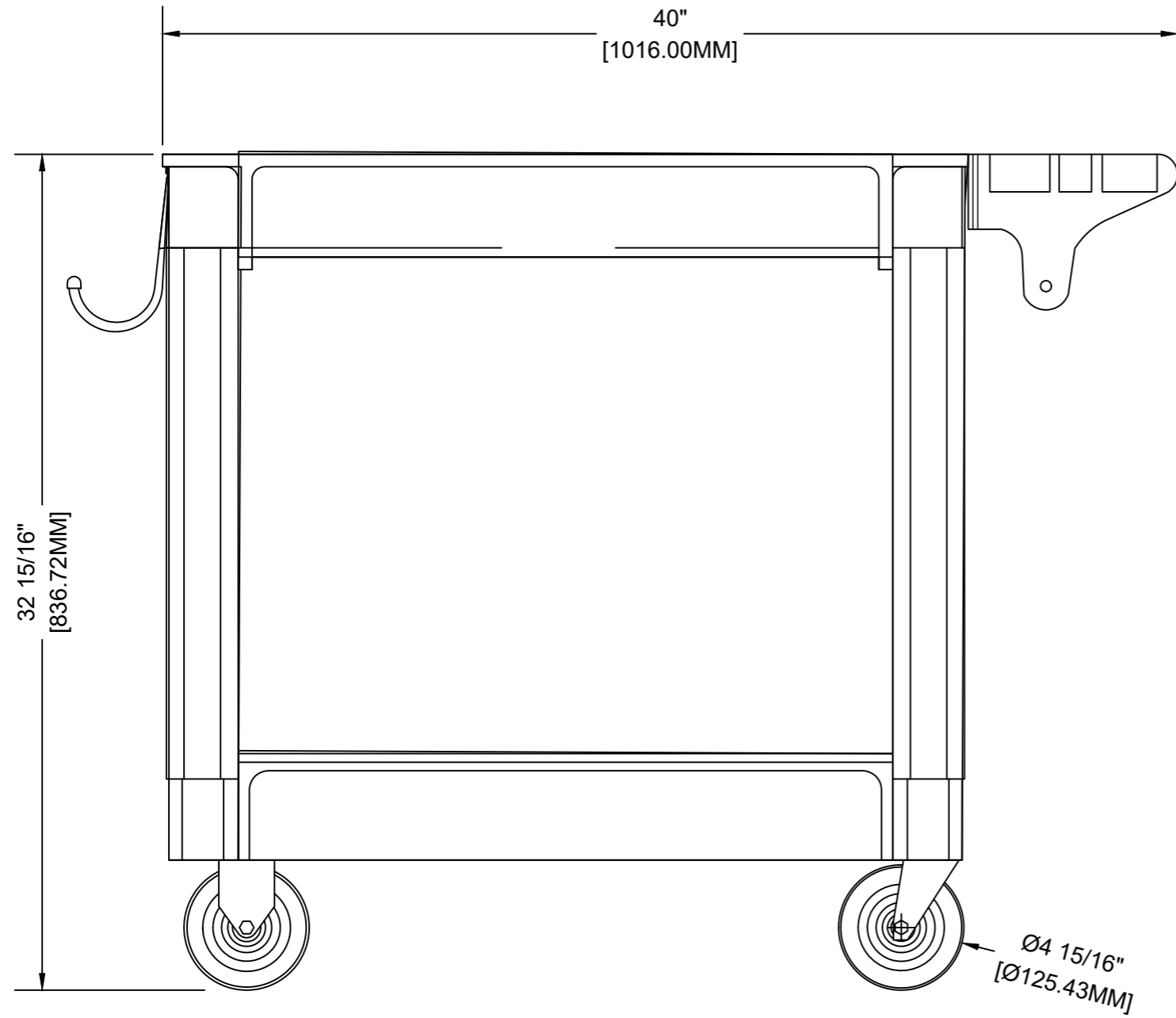

FRONT VIEW

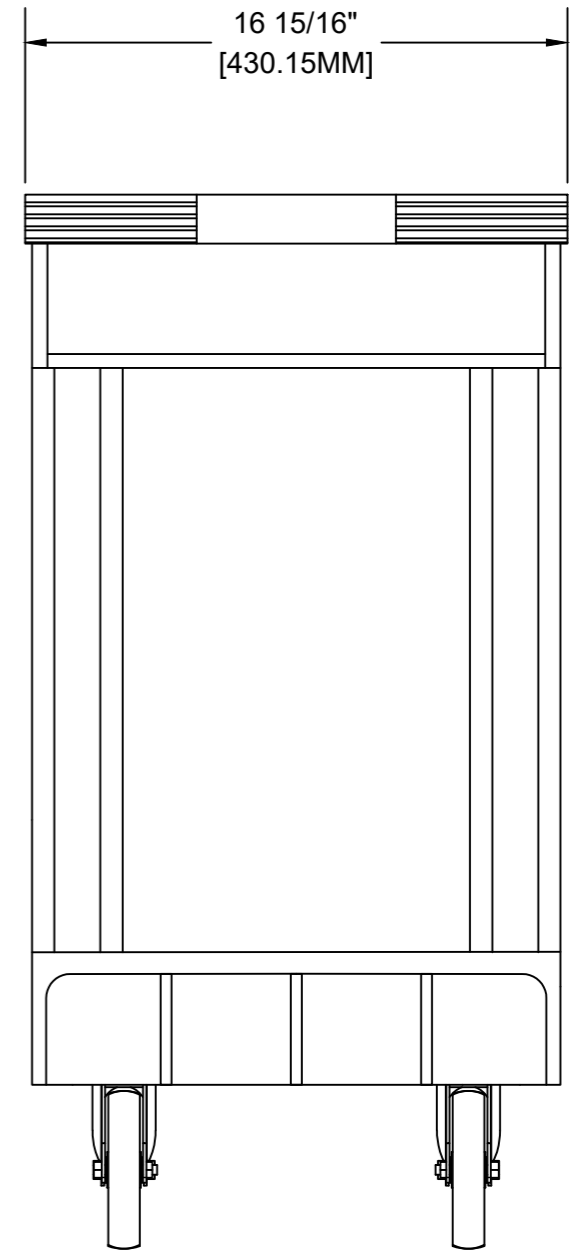

RIGHT VIEW