

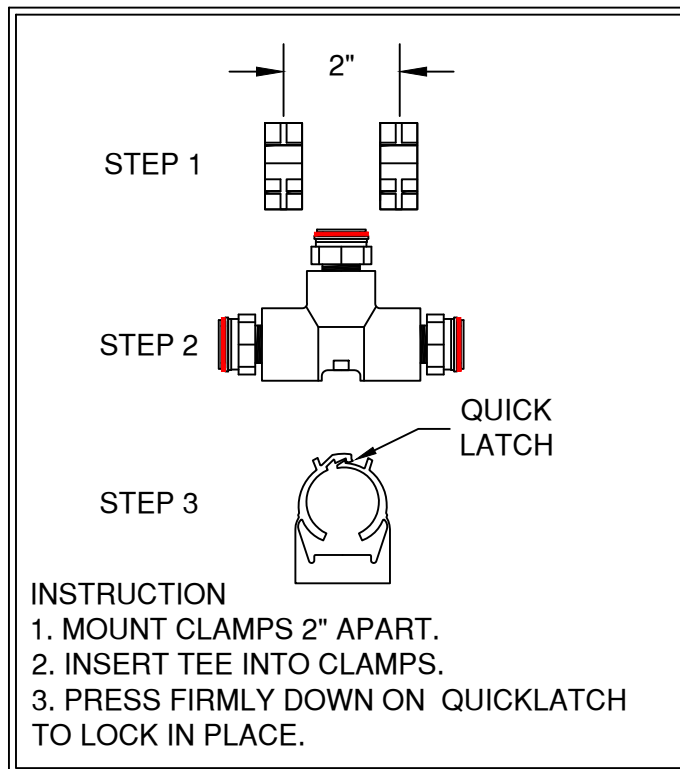

WALL MOUNT UNIT 1.5/3.5 GPM COMBINATION

DRAWING INDEX		
DRAWING #	DRAWING DESCRIPTION	REVISION
CUE4-01	COVER PAGE	1
CUE4-02	INSTALLATION	1
CUE4-03	DIMENSIONS	1

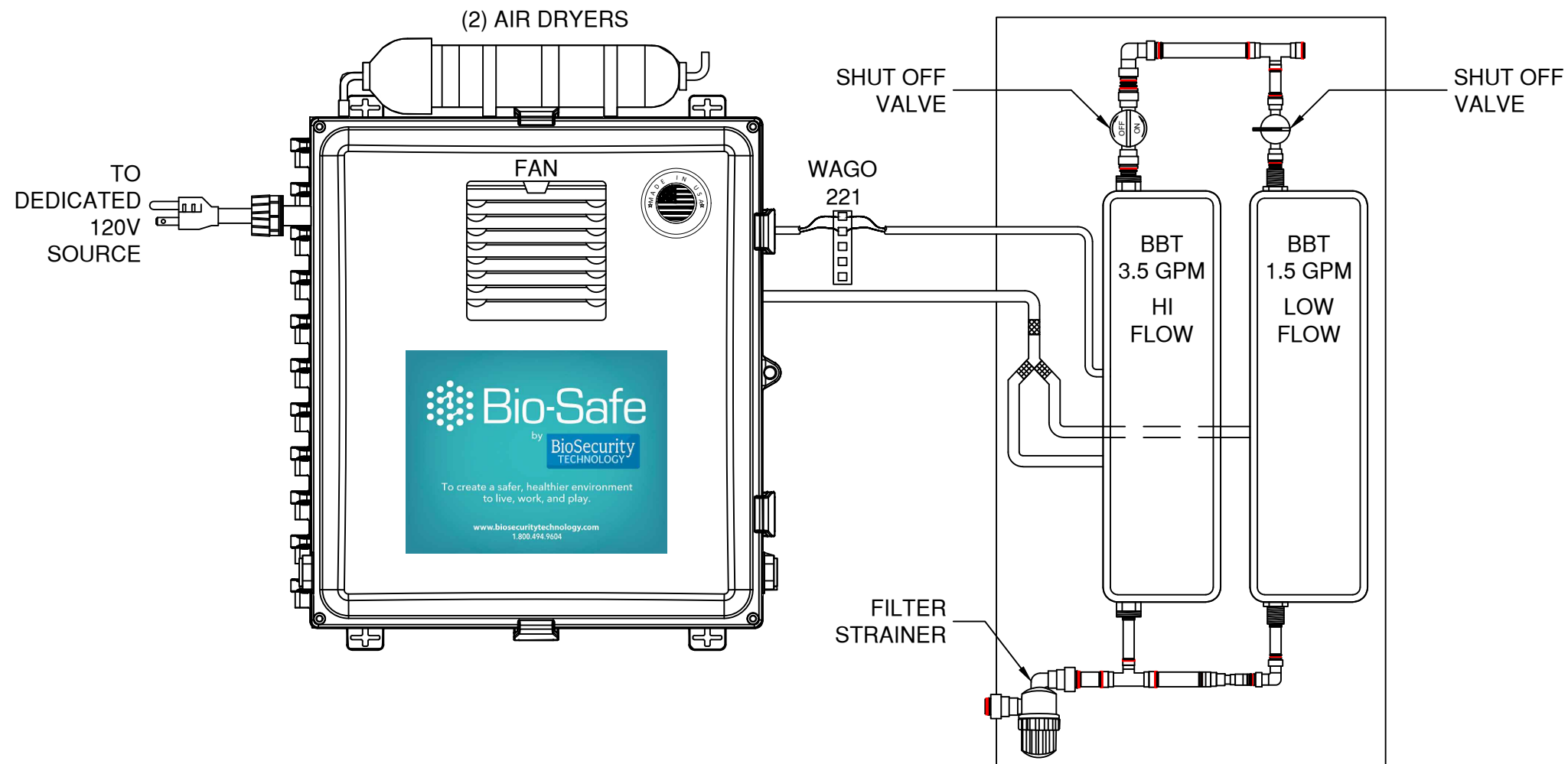

DETAIL A
PROBE ASSEMBLY

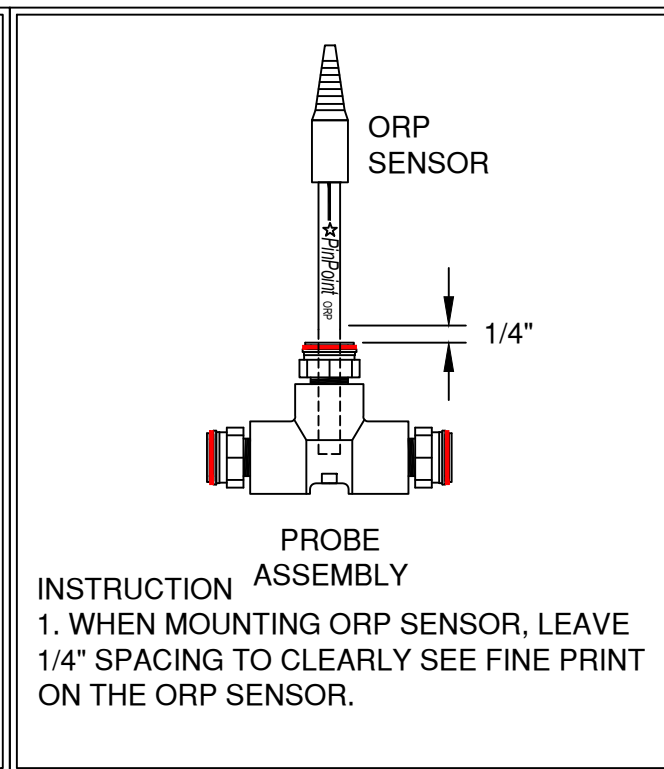

DETAIL B
ORP SENSOR

BIO-SAFE INSTALLATION

1. LOCATE THE COLD-WATER SUPPLY AND TURN IT OFF.
2. REMOVE WATER SUPPLY TO SINK FROM VALVE.
3. INSTALL MOP SINK ADAPTER AND RE-CONNECT TO SUPPLY LINE THAT LEADS TO SINK. CHECK THAT VALVE IS "OFF" ON STOP-TEE. NOW YOU CAN TURN WATER BACK ON TO SINK.
4. MOUNT BIO-SAFE UNIT REASONABLY CLOSE TO SUPPLY LINE CONNECTION.
5. MOUNT BLACKBOX TECHNOLOGY BOARD REASONABLY CLOSE TO BIO-SAFE UNIT.
6. MUST BE DEDICATED 120V POWER OUTLET.
7. CONNECT BLACKBOX TUBING TO BIO-SAFE UNIT.
8. CONNECT BLACK AND RED WIRES TO WAGO 1221.

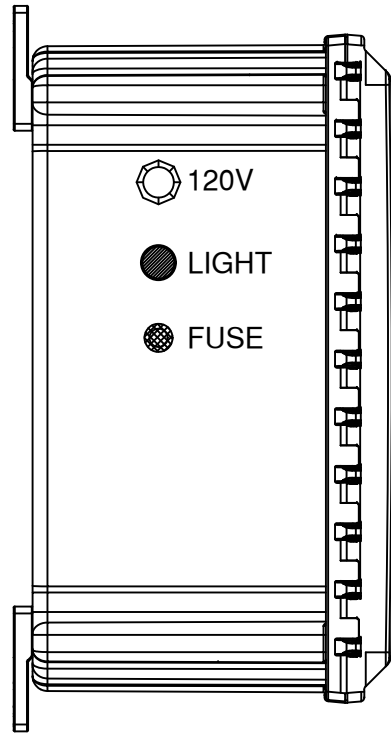

LEFT VIEW

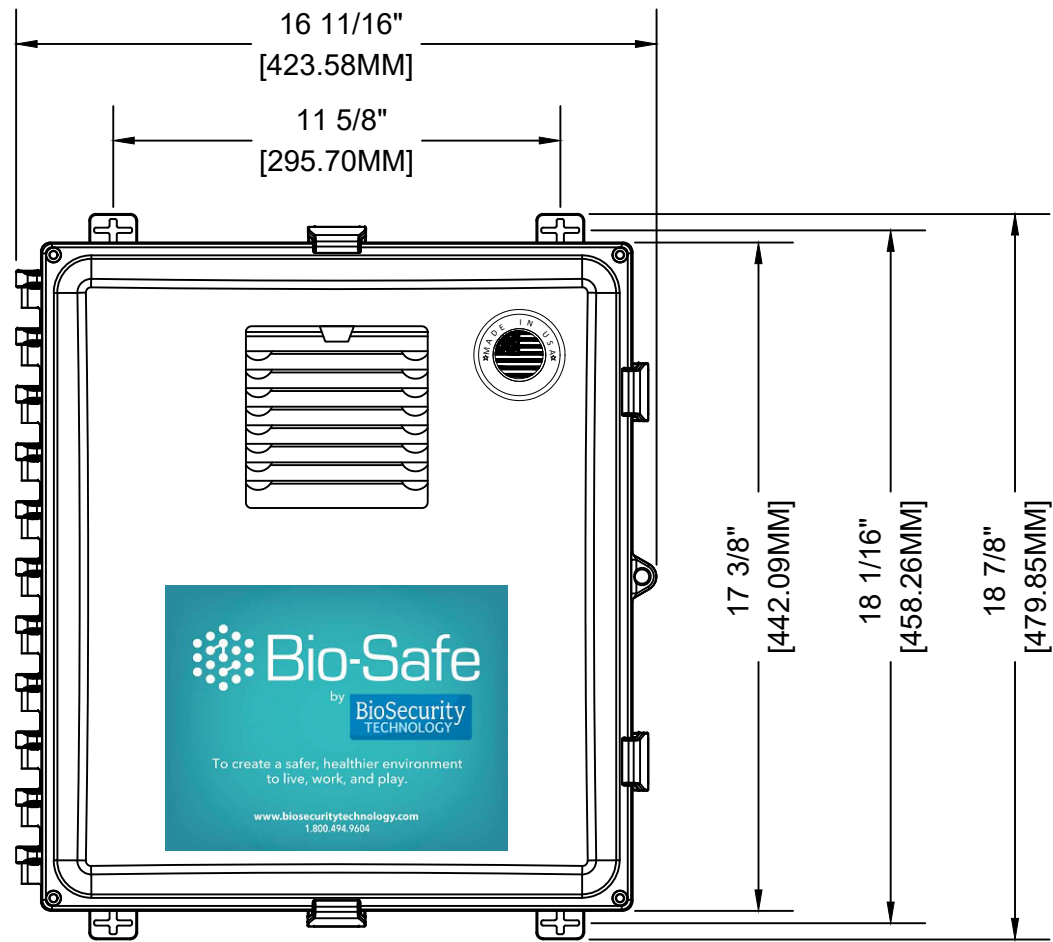

FRONT VIEW

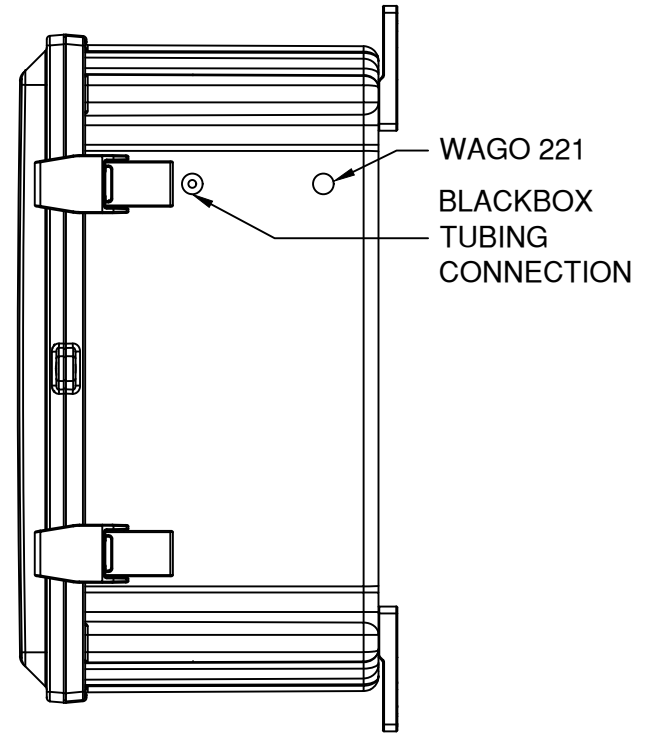

RIGHT VIEW

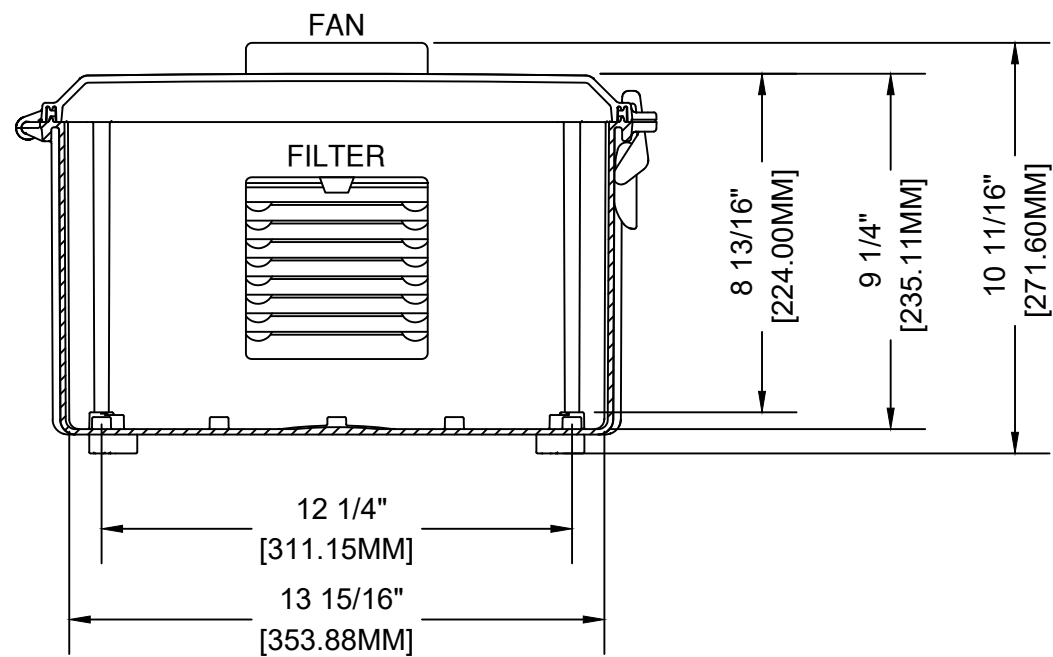

BOTTOM VIEW